

# BEDIENUNGSANLEITUNG CRIMPZANGE 16/4S

## OPERATING INSTRUCTIONS CRIMPING TOOL 16/4S

0.08–16.0 mm<sup>2</sup>

Art. 0714 107 162

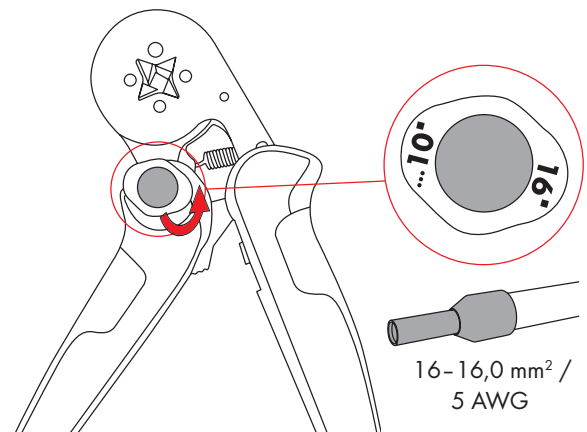
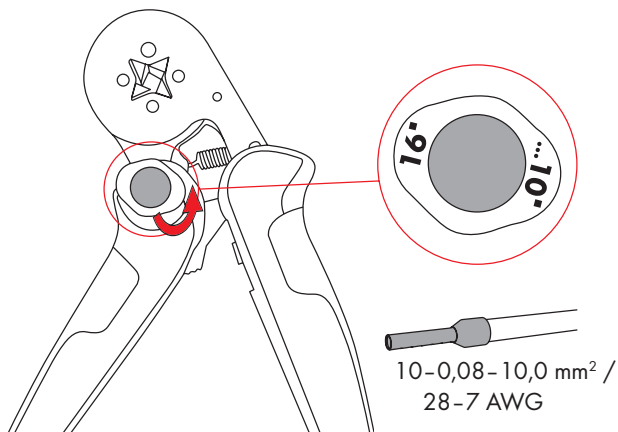
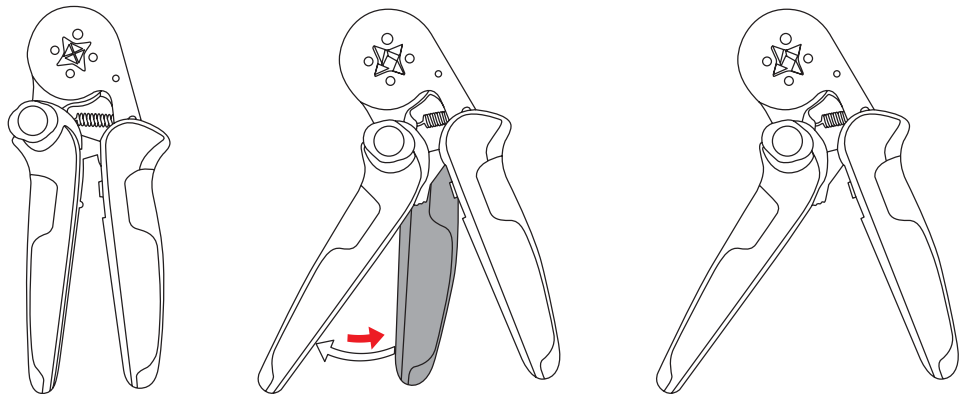

**Vorsicht**  
**Caution**



Benutzen Sie eine Sicherheitsbrille um Ihre Augen zu schützen  
Use safety glasses to avoid eye injury